

Project 3

Angle Clamp Assembly

In this project, you will create components for a Angle Clamp assembly and then assemble them. You need to create all the components as separate part files. The views and dimensions of the components are shown in Figures P3-3 through P3-13.

You can also download the model files for your reference from www.cadcim.com. To download the files, use the following path: *Textbooks > CAD/CAM > Siemens NX > Siemens NX 2020 for Designers, 13th Edition > Projects for Free Download > Project 3*

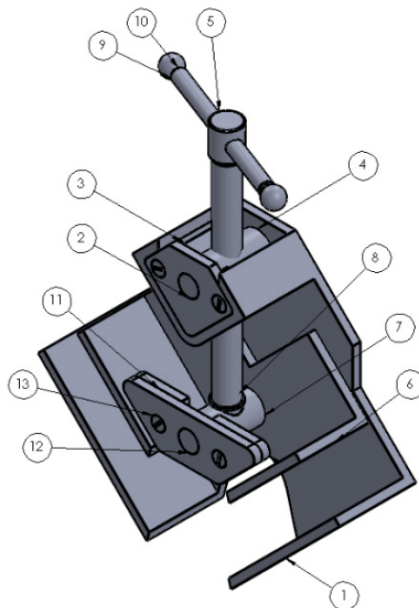

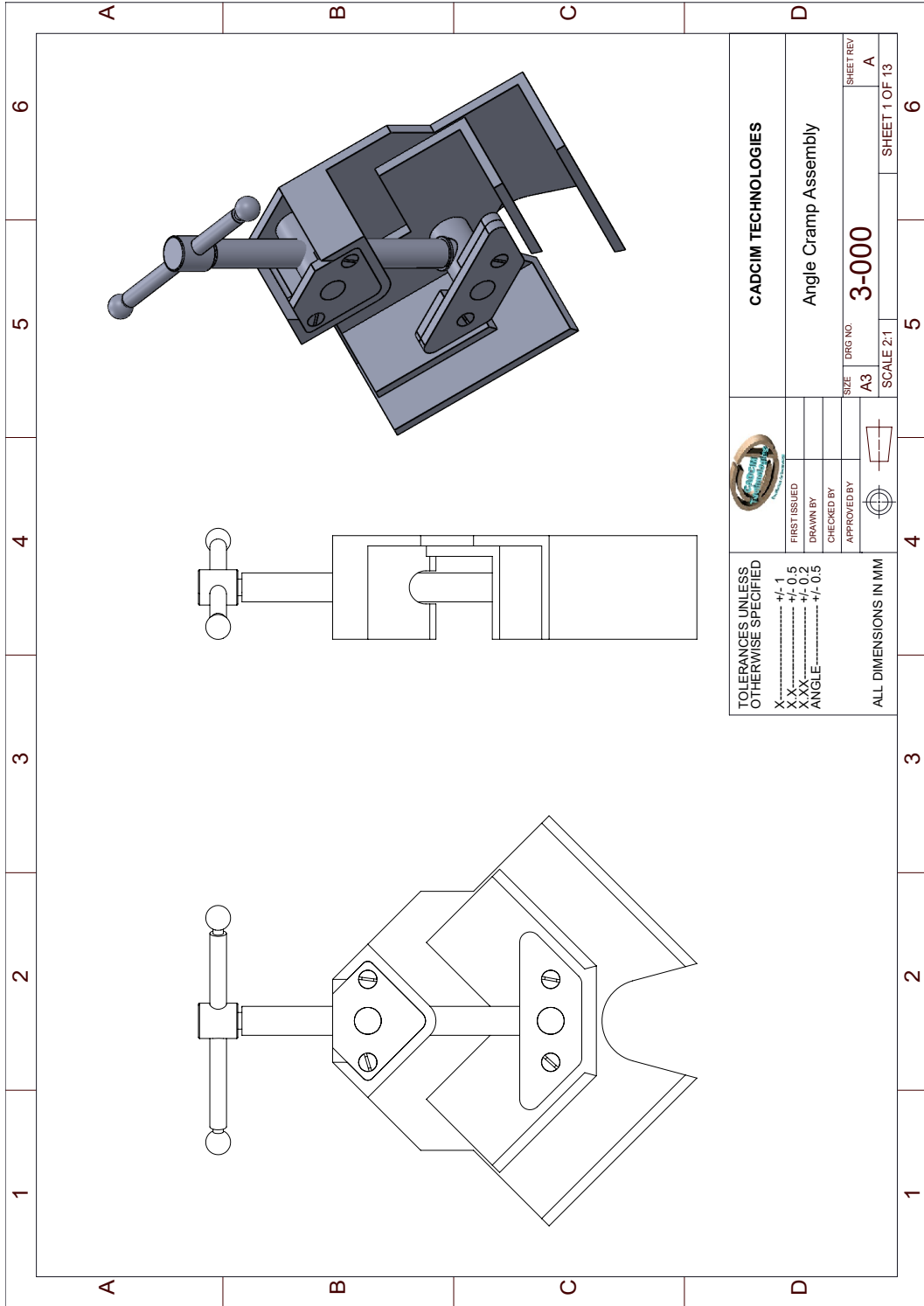

Figure P3-1 The Angle Cramp assembly

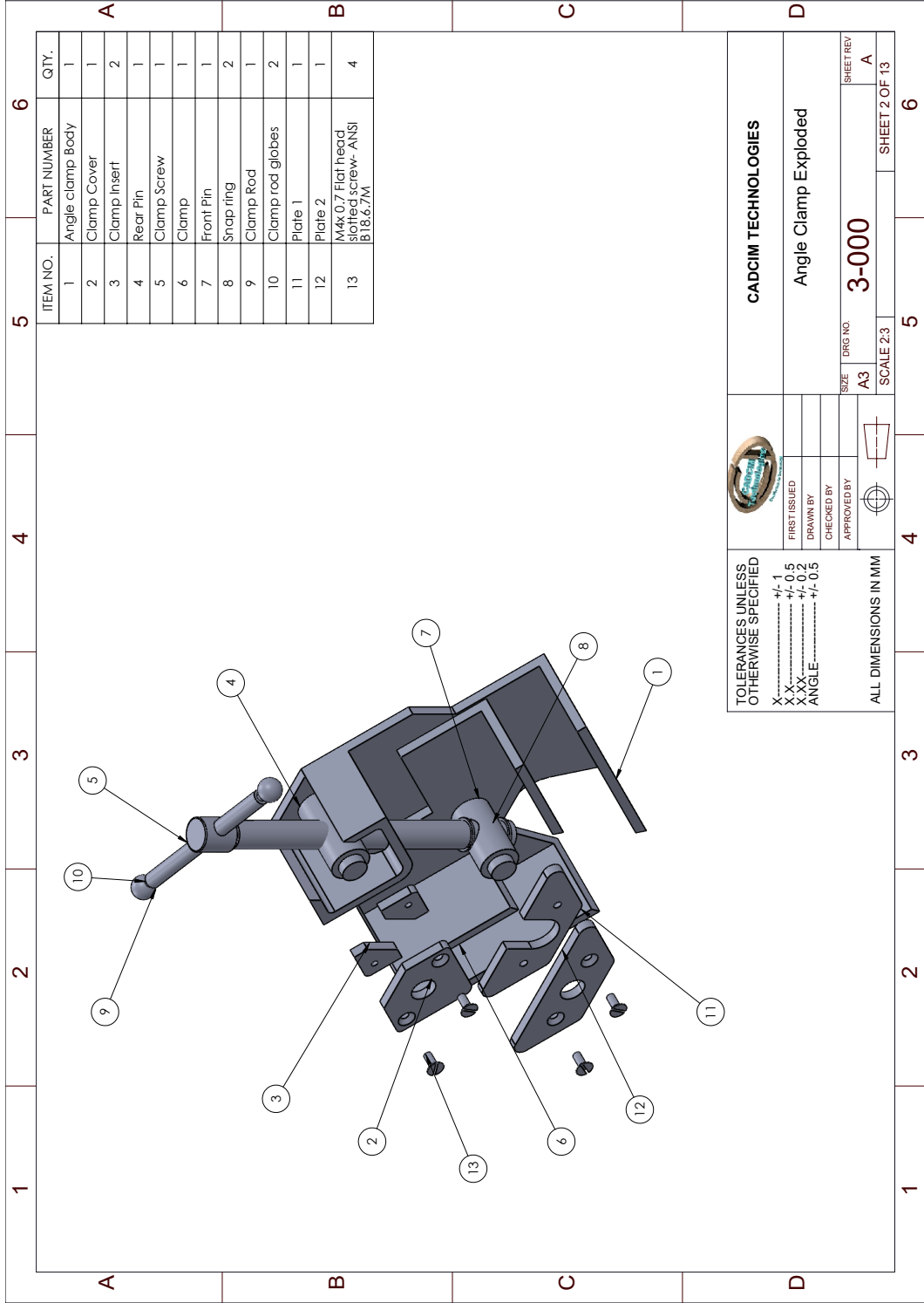

Figure P3-2 The exploded view of Angle Clamp assembly

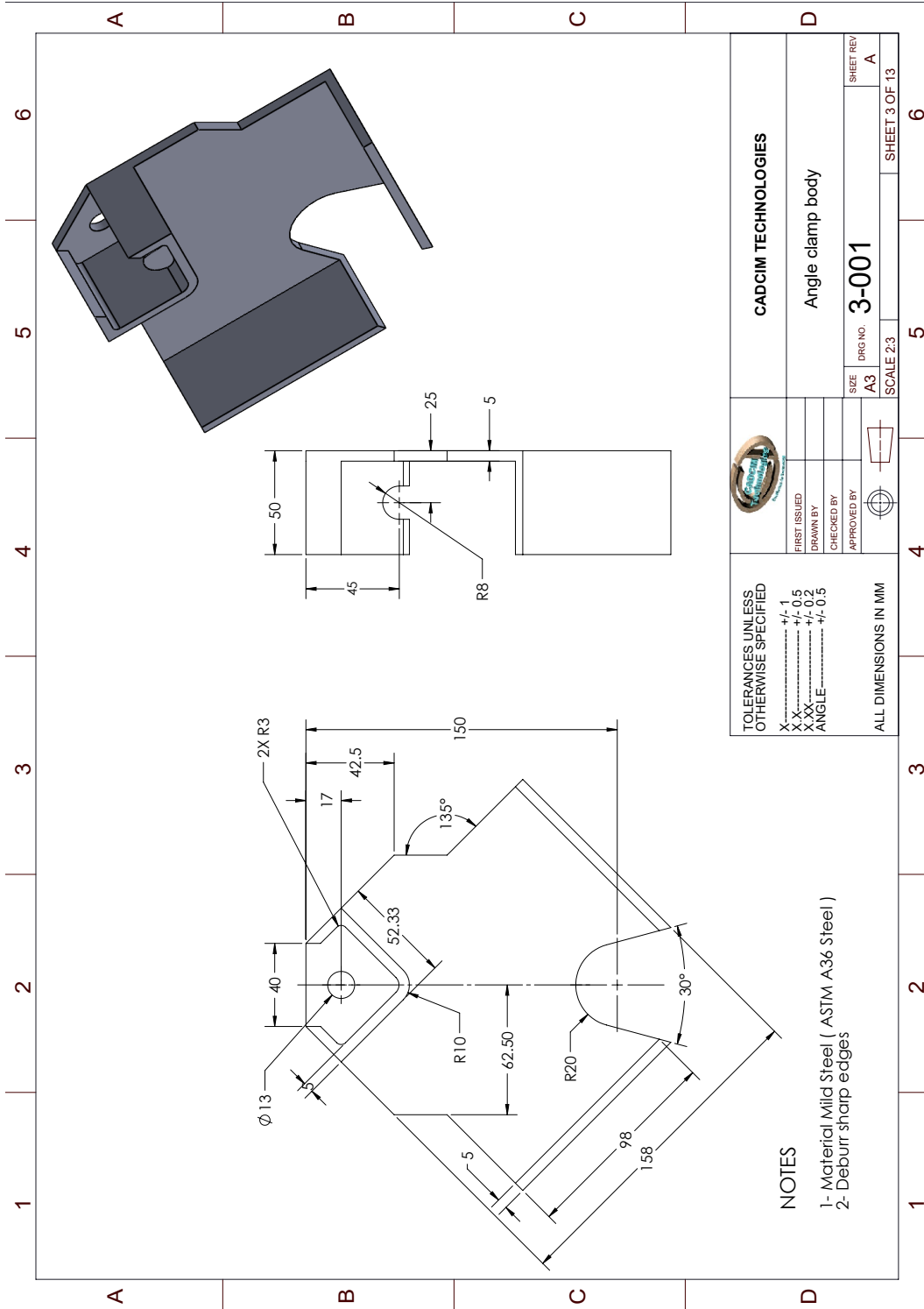

Figure P3-3 Views and dimensions of Angle Clamp Body

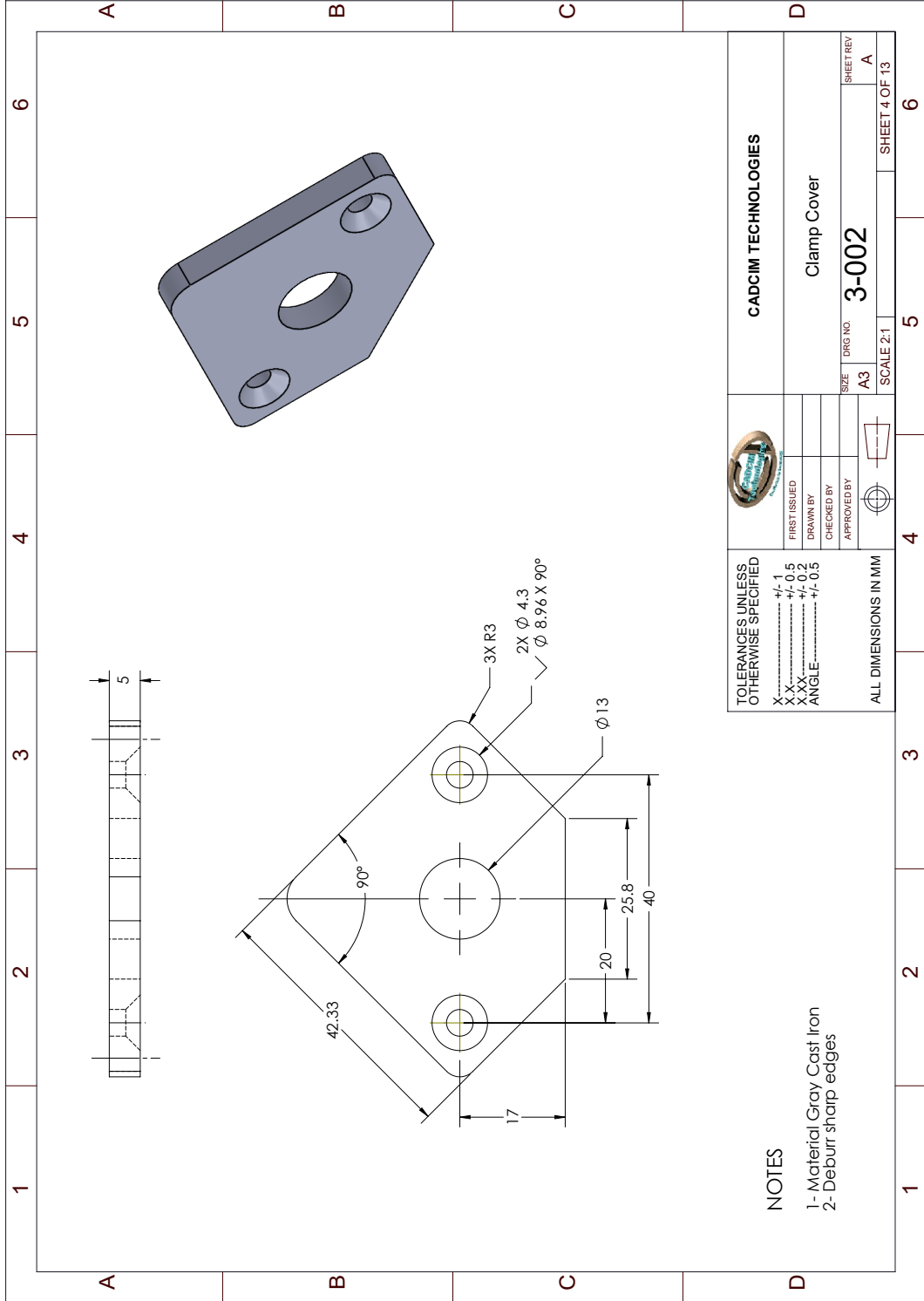

Figure P3-4 Views and dimensions of Clamp Cover

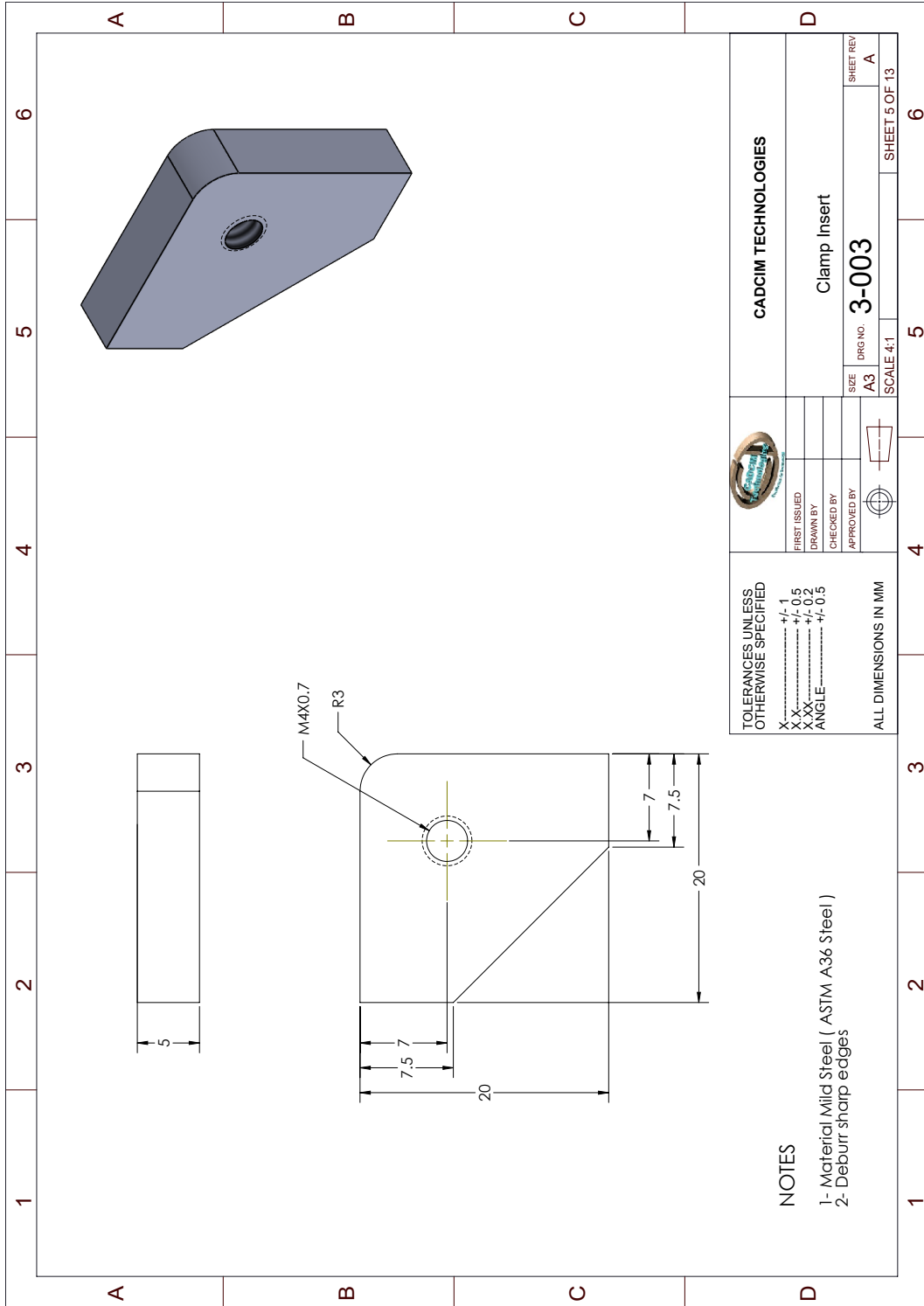

Figure P3-5 Views and dimensions of Clamp Insert

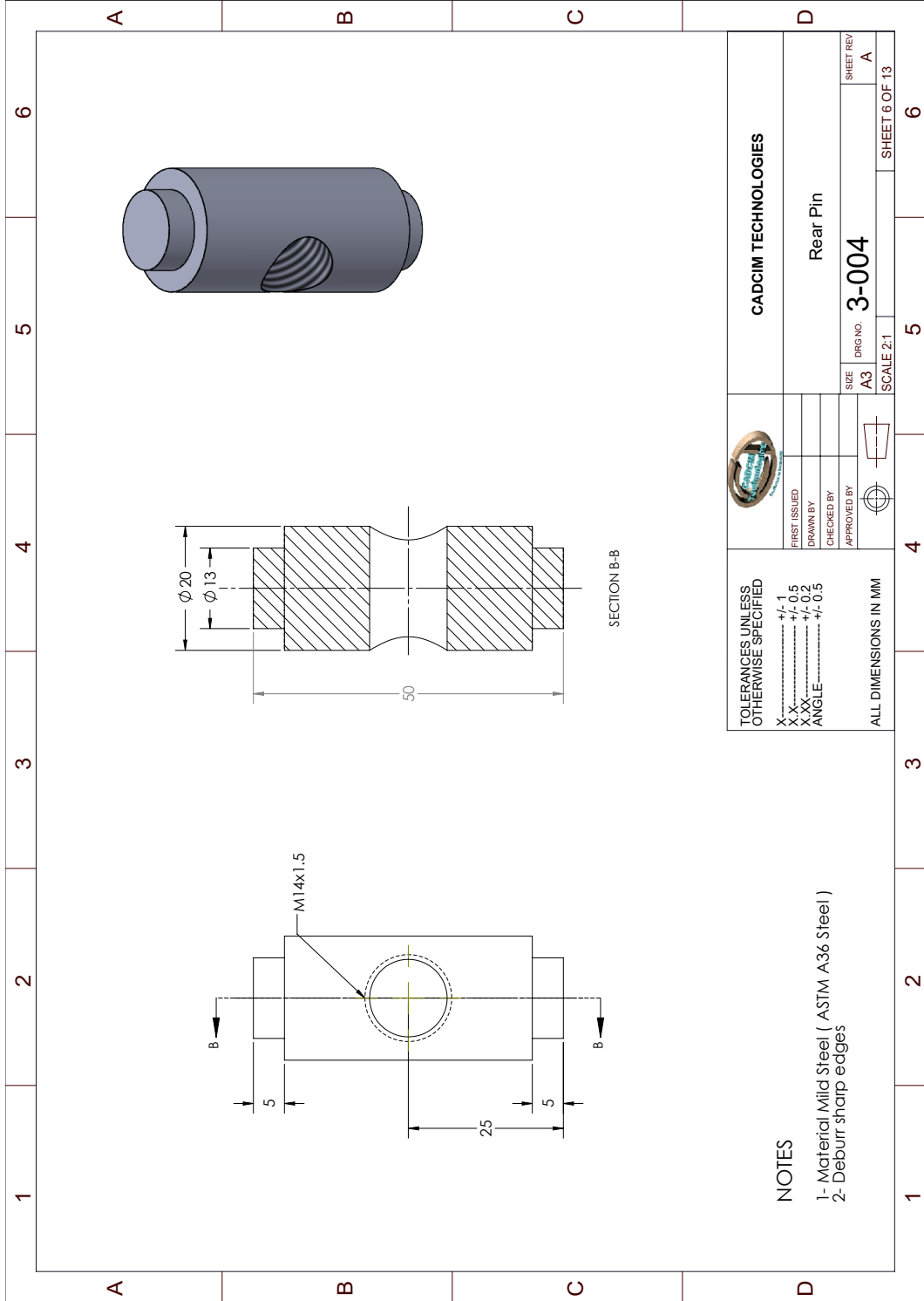

Figure P3-6 Views and dimensions of Rear Pin

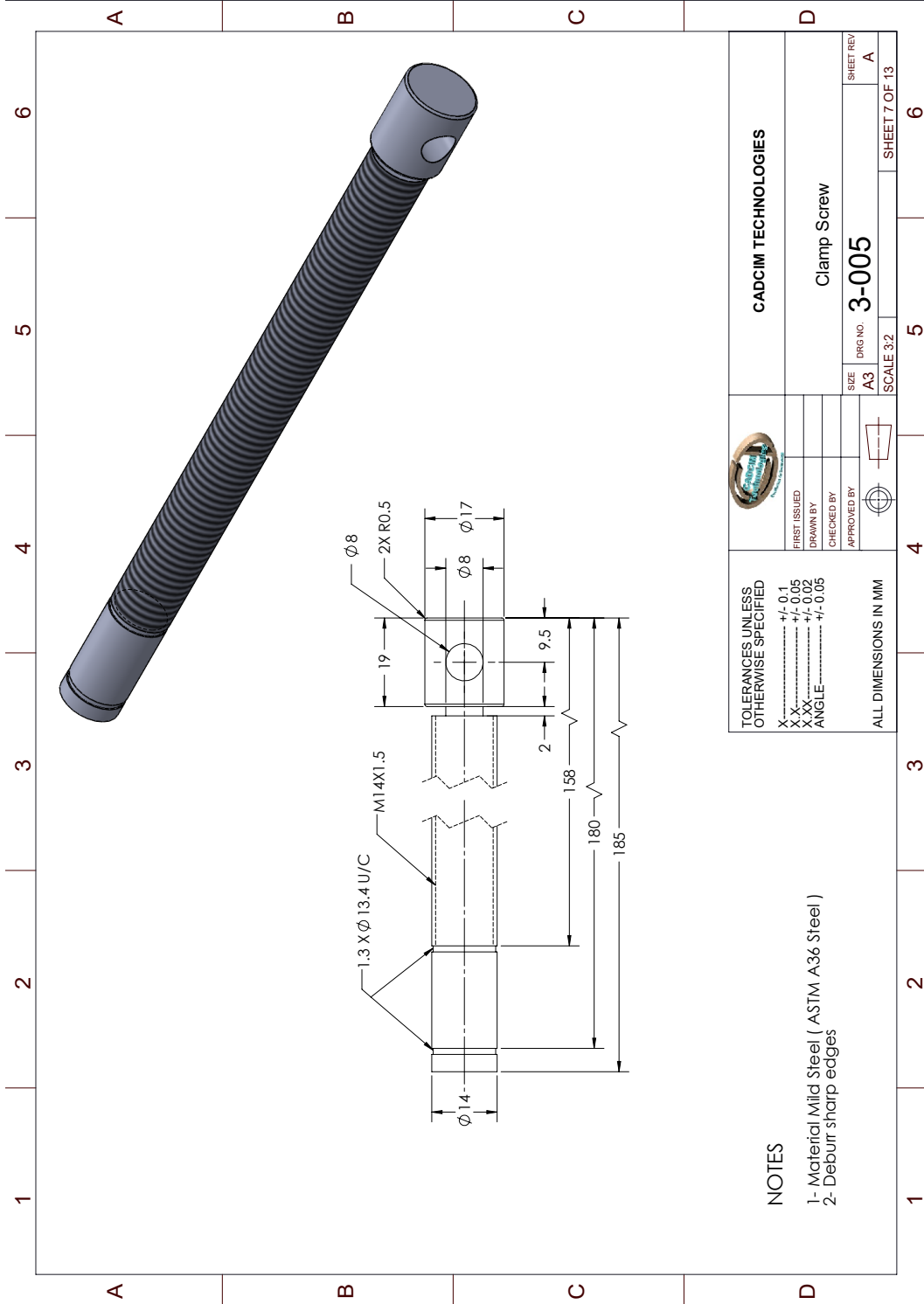

Figure P3-7 Views and dimensions of Clamp Screw

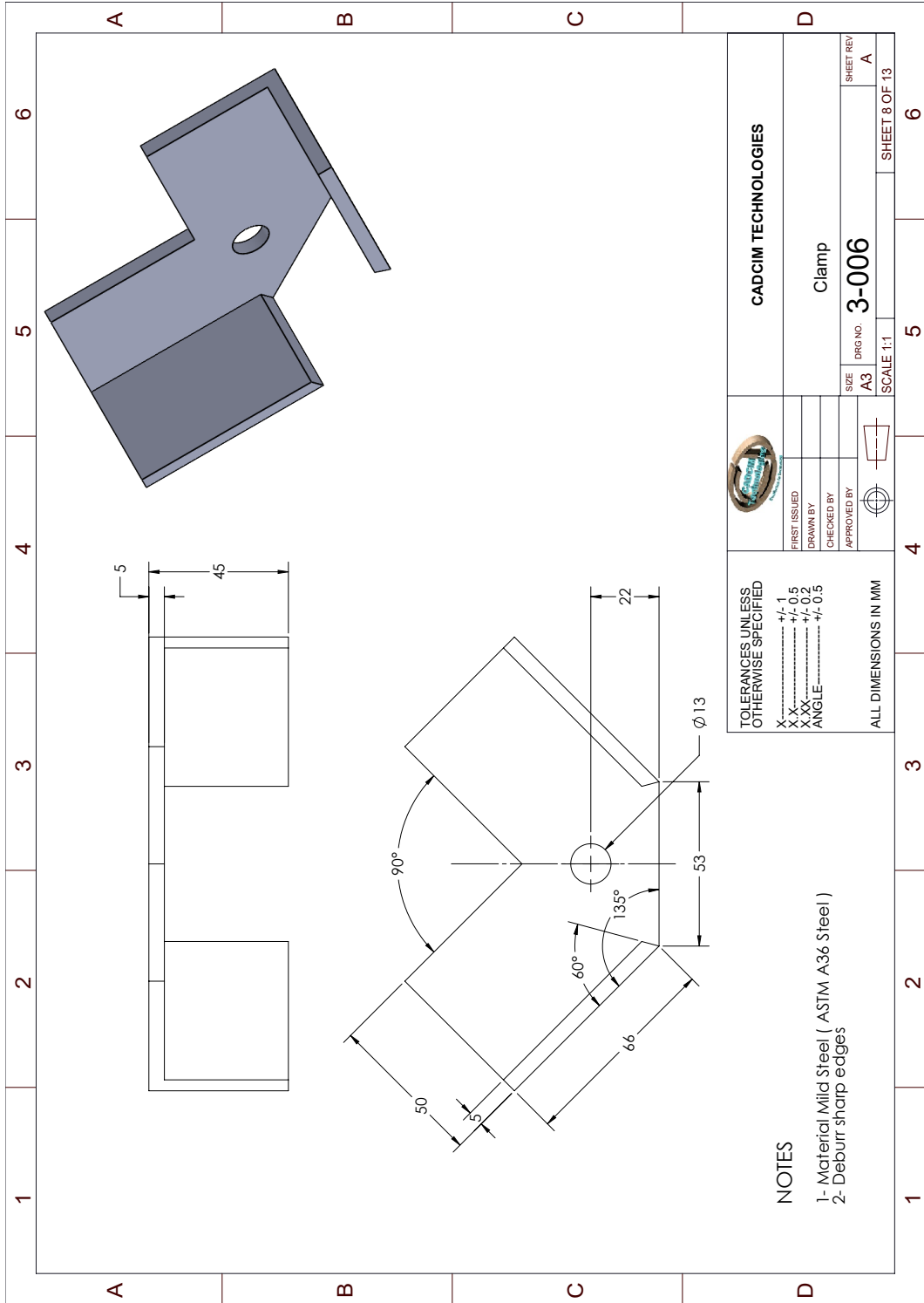

Figure P3-8 Views and dimensions of Clamp

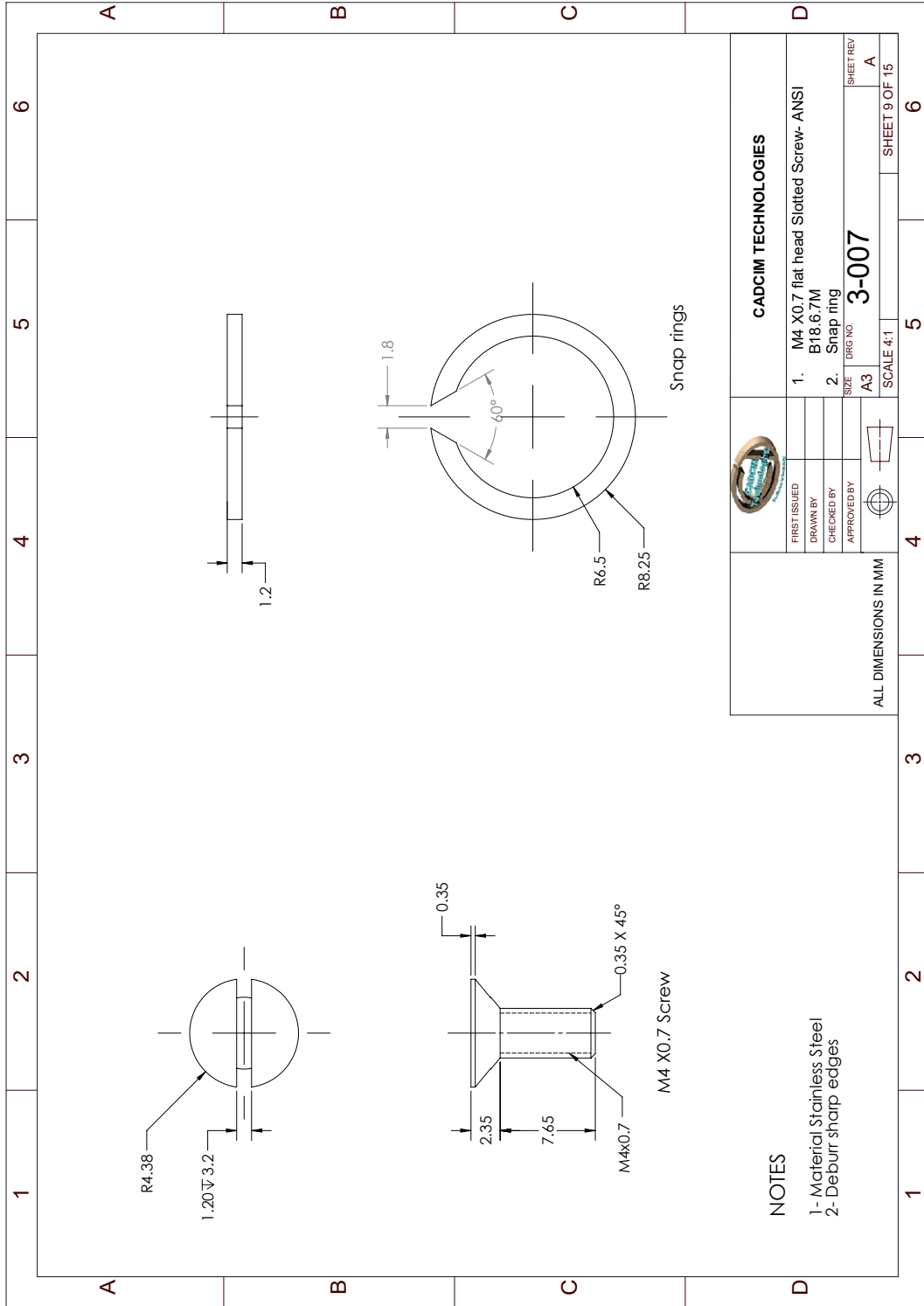

Figure P3-9 Views and dimensions of M4 X 0.7 flat head slotted screw

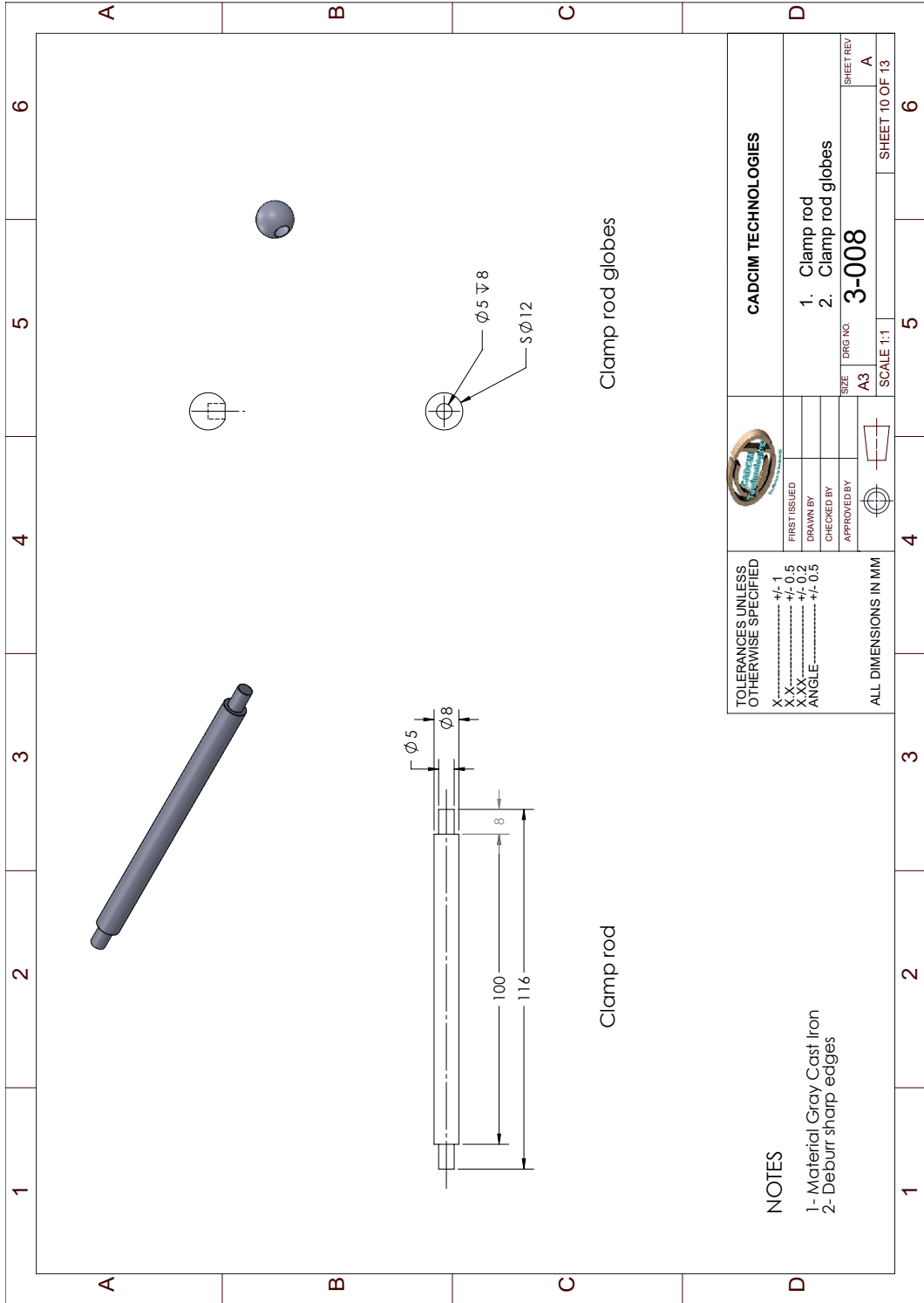

Figure P3-10 Views and dimensions of Clamp Rod and Clamp Rod Globes

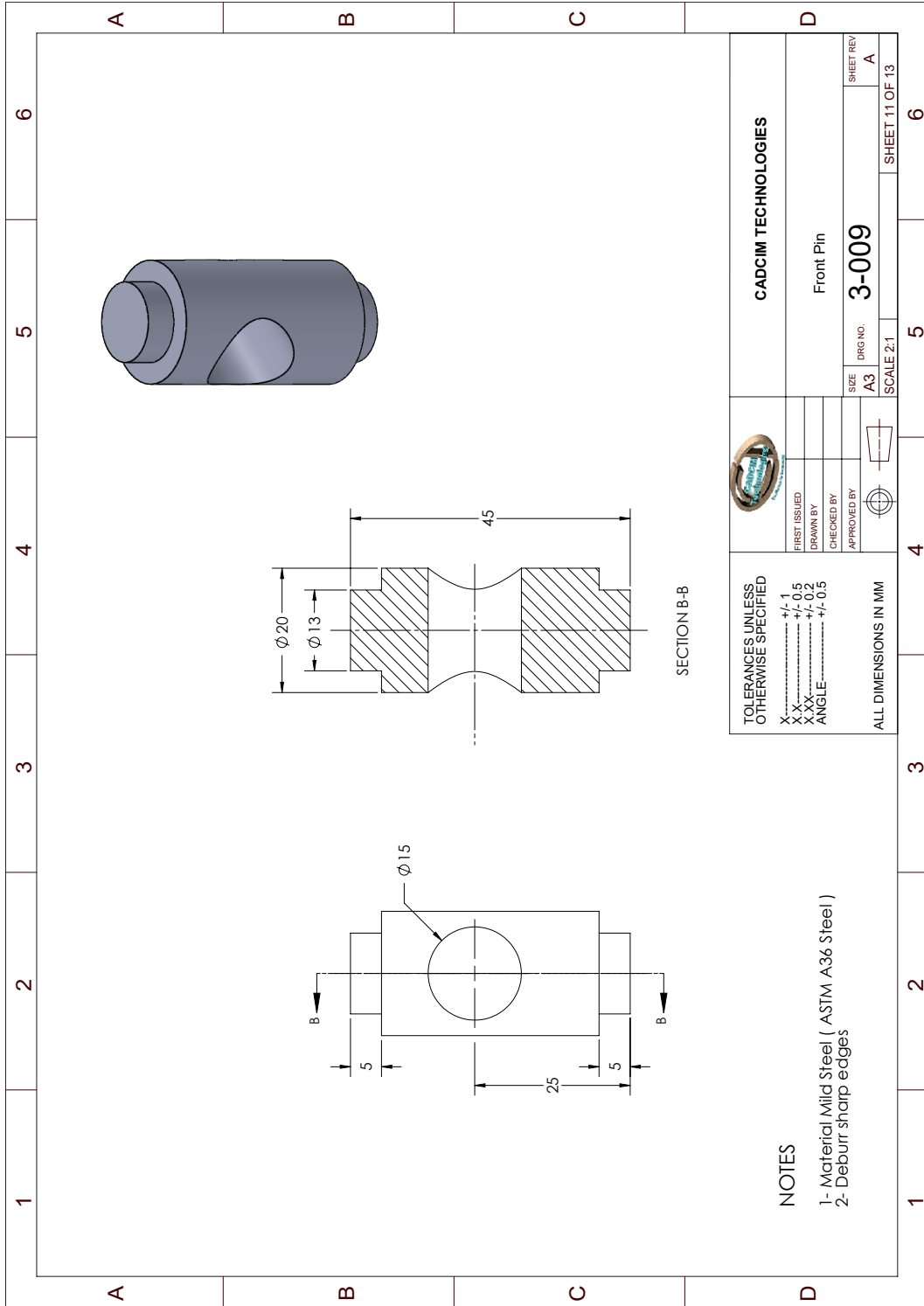

Figure P3-11 Views and dimensions of Front Pin

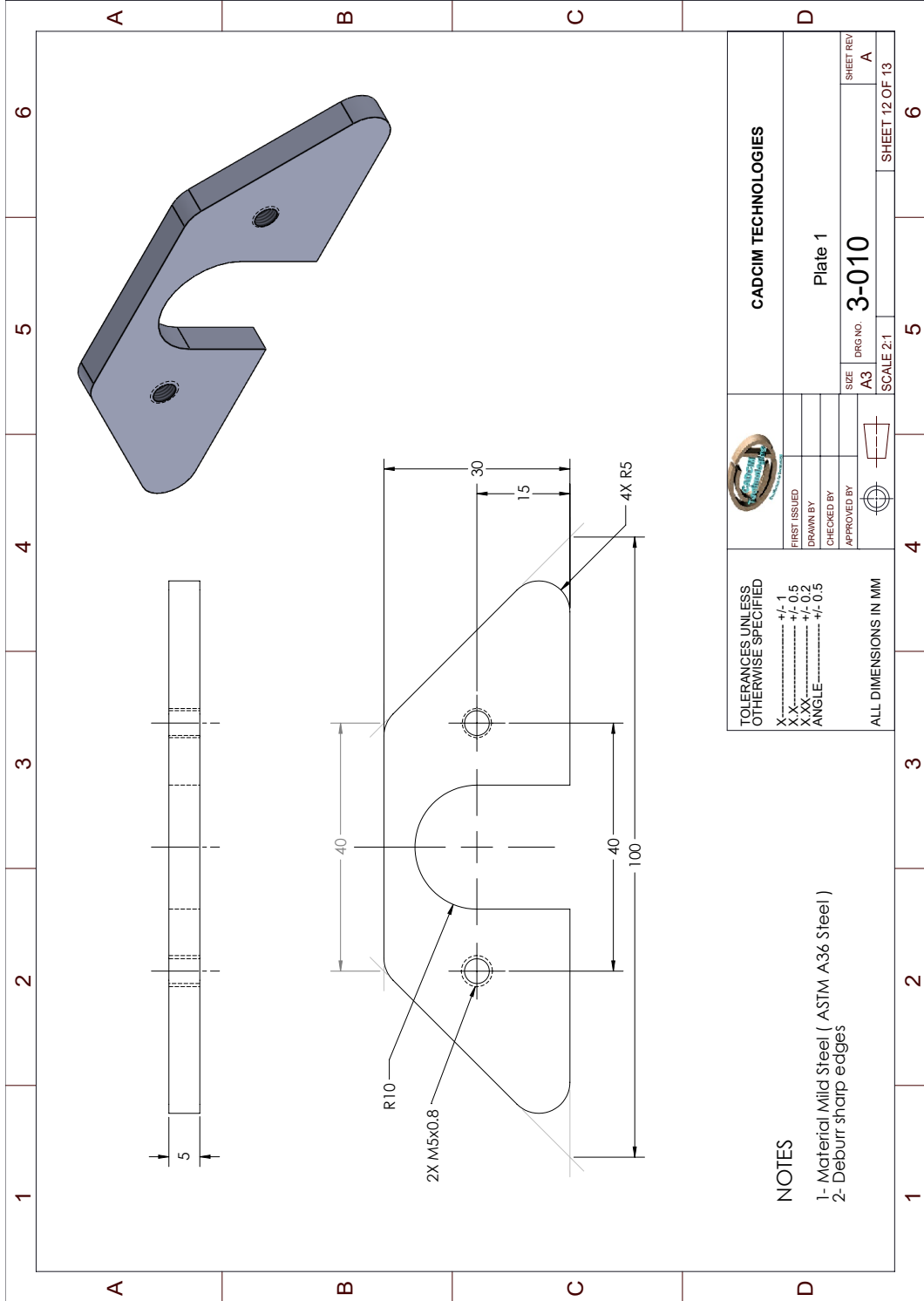

Figure P3-12 Views and dimensions of Plate 1

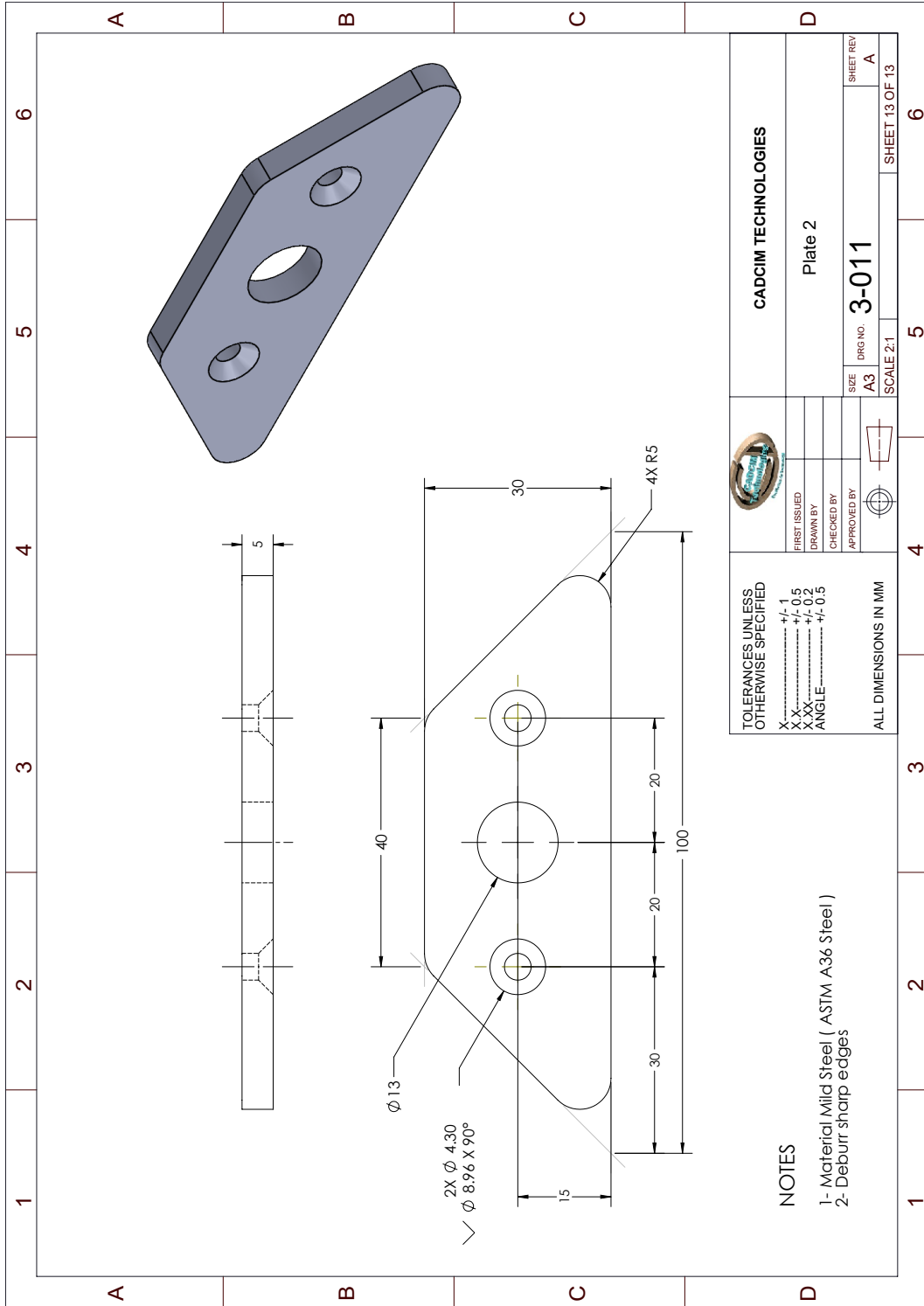

Figure P3-13 Views and dimensions of Plate 2