

Project 2

Wheel Assembly

In this project, you will create components for a Wheel assembly and then assemble them. You need to create all the components as separate part files. The views and dimensions of the components are shown in Figures P2-2 through P2-5.

You can also download the model files for your reference from www.cadcim.com. To download the files, use the following path: *Textbooks > CAD/CAM > Siemens NX > Siemens NX 2020 for Designers, 13th Edition > Projects for Free Download > Project 2*

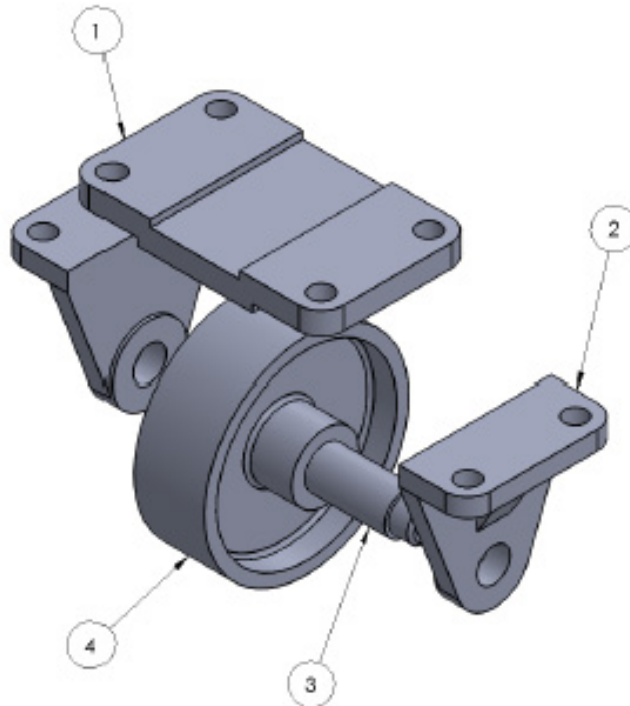

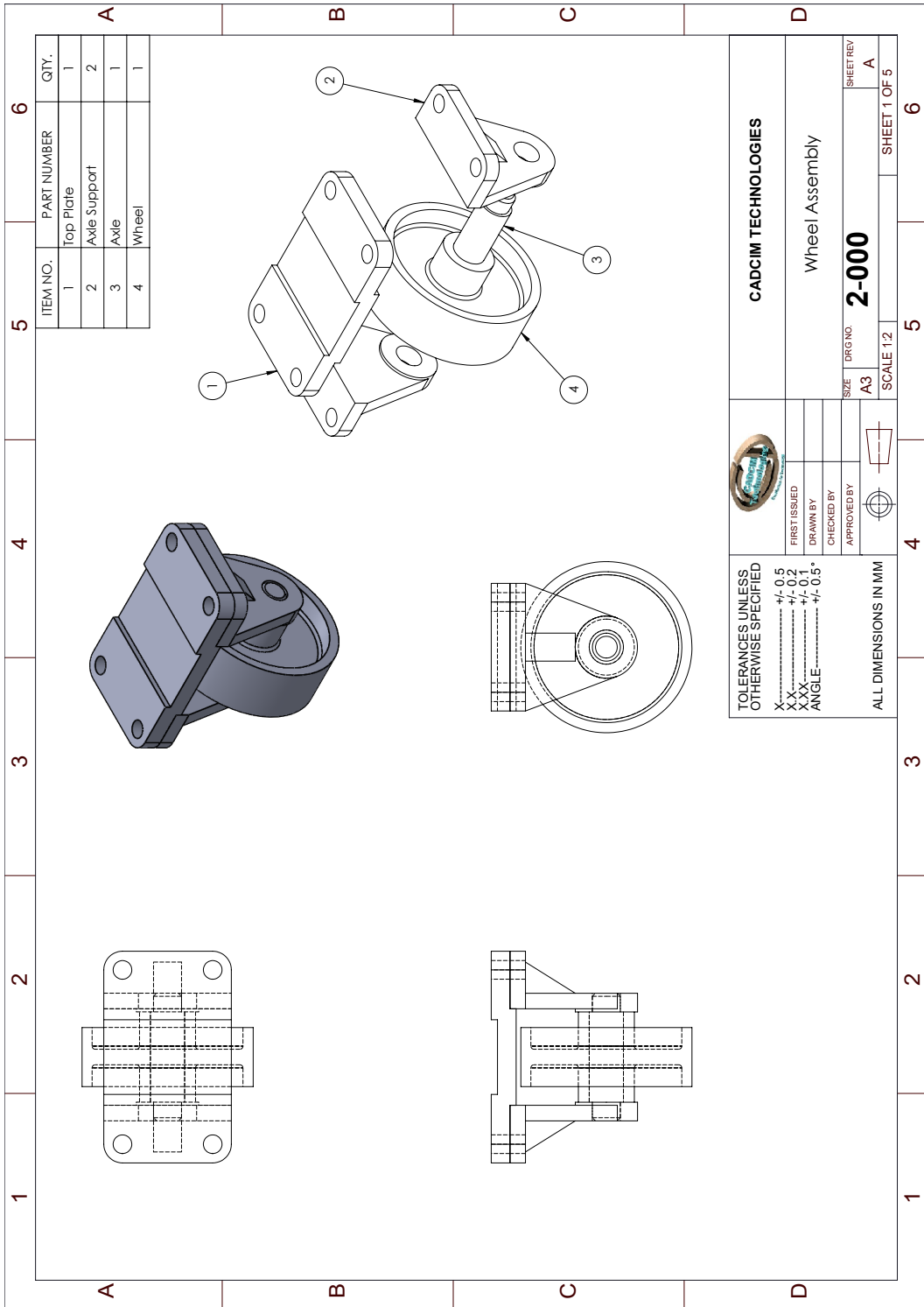

Figure P2-1 The Wheel assembly

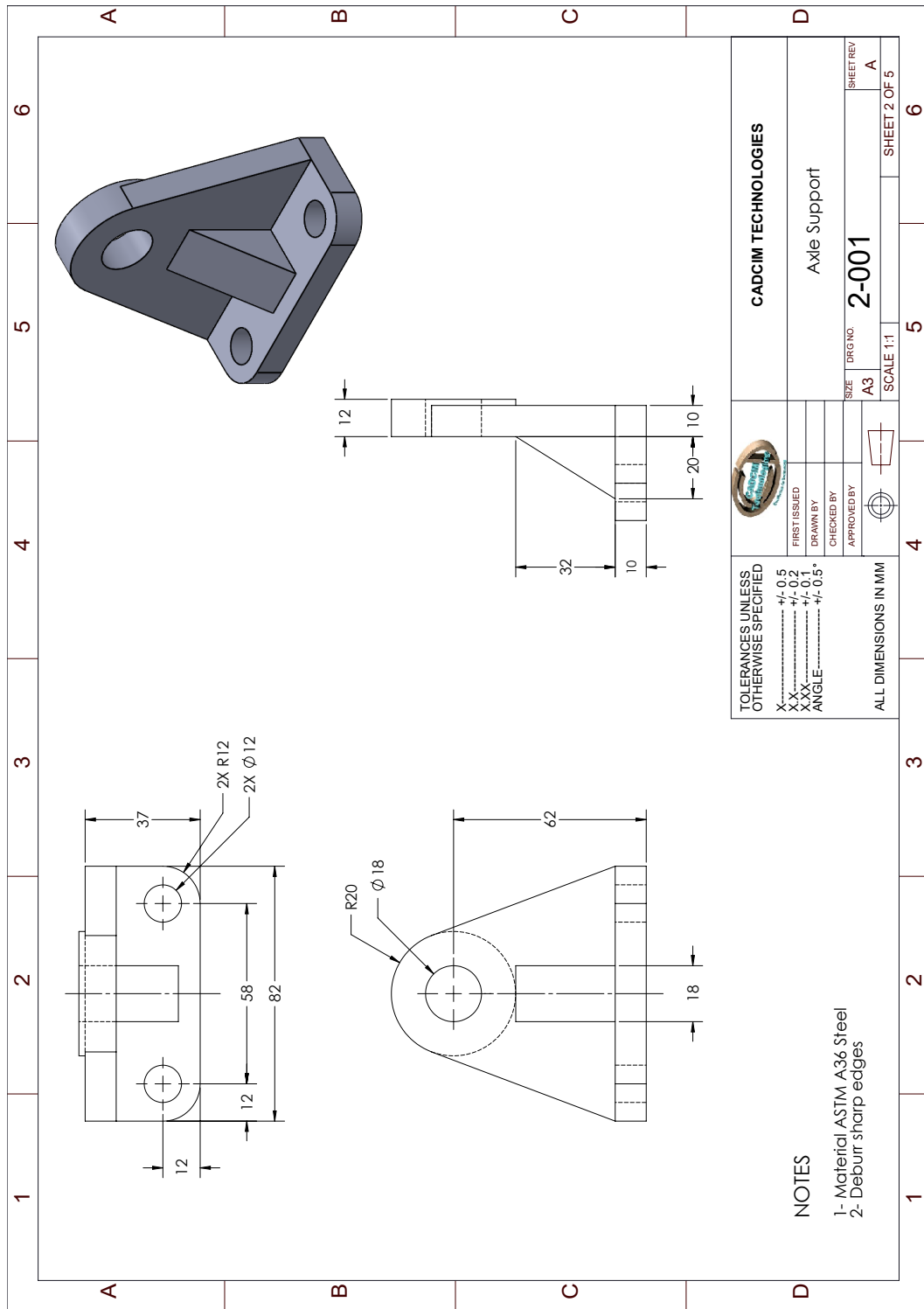

Figure P2-2 Views and dimensions of Axle Support

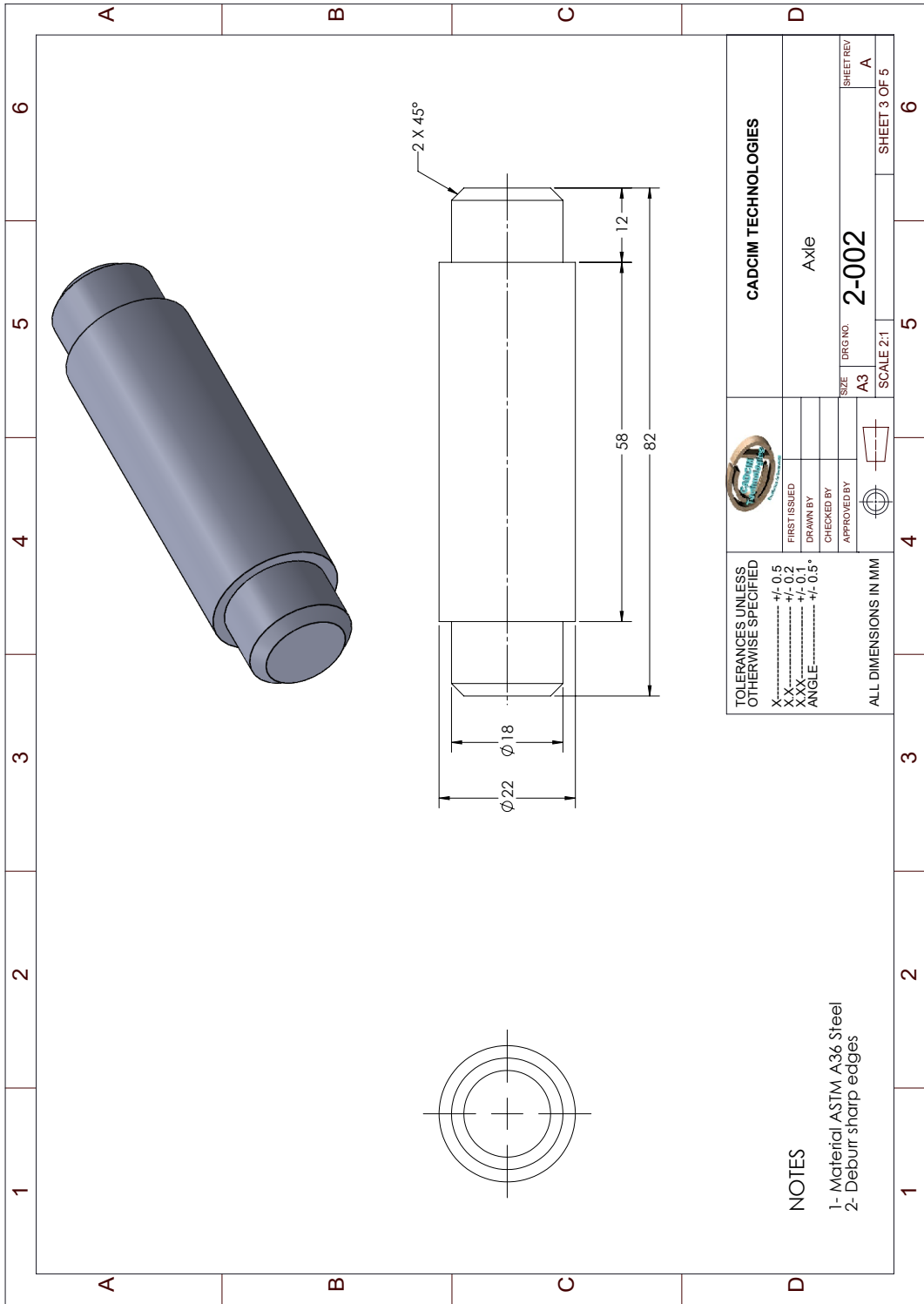

Figure P2-3 Views and dimensions of Axle

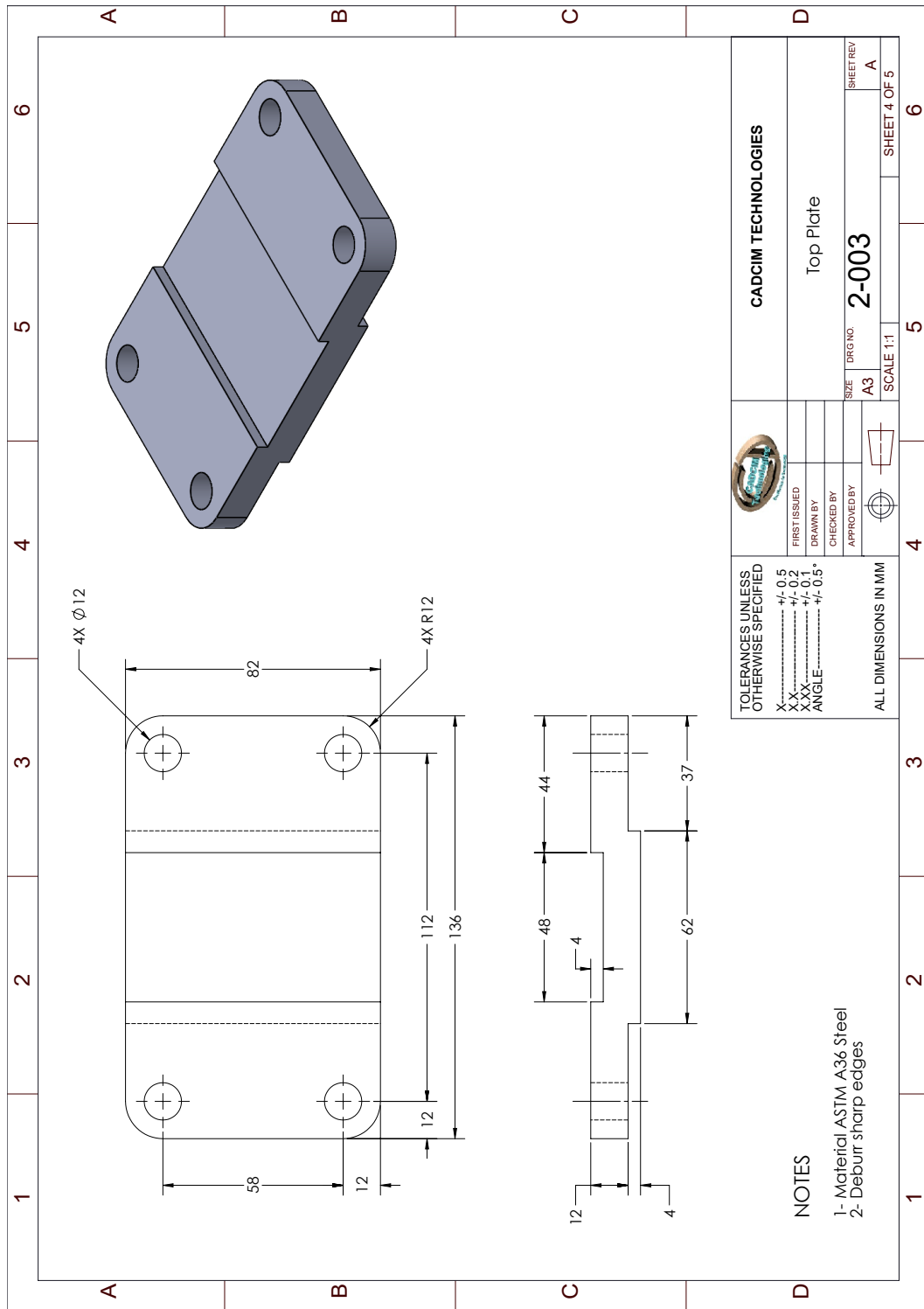

Figure P2-4 Views and dimensions of Top Plate

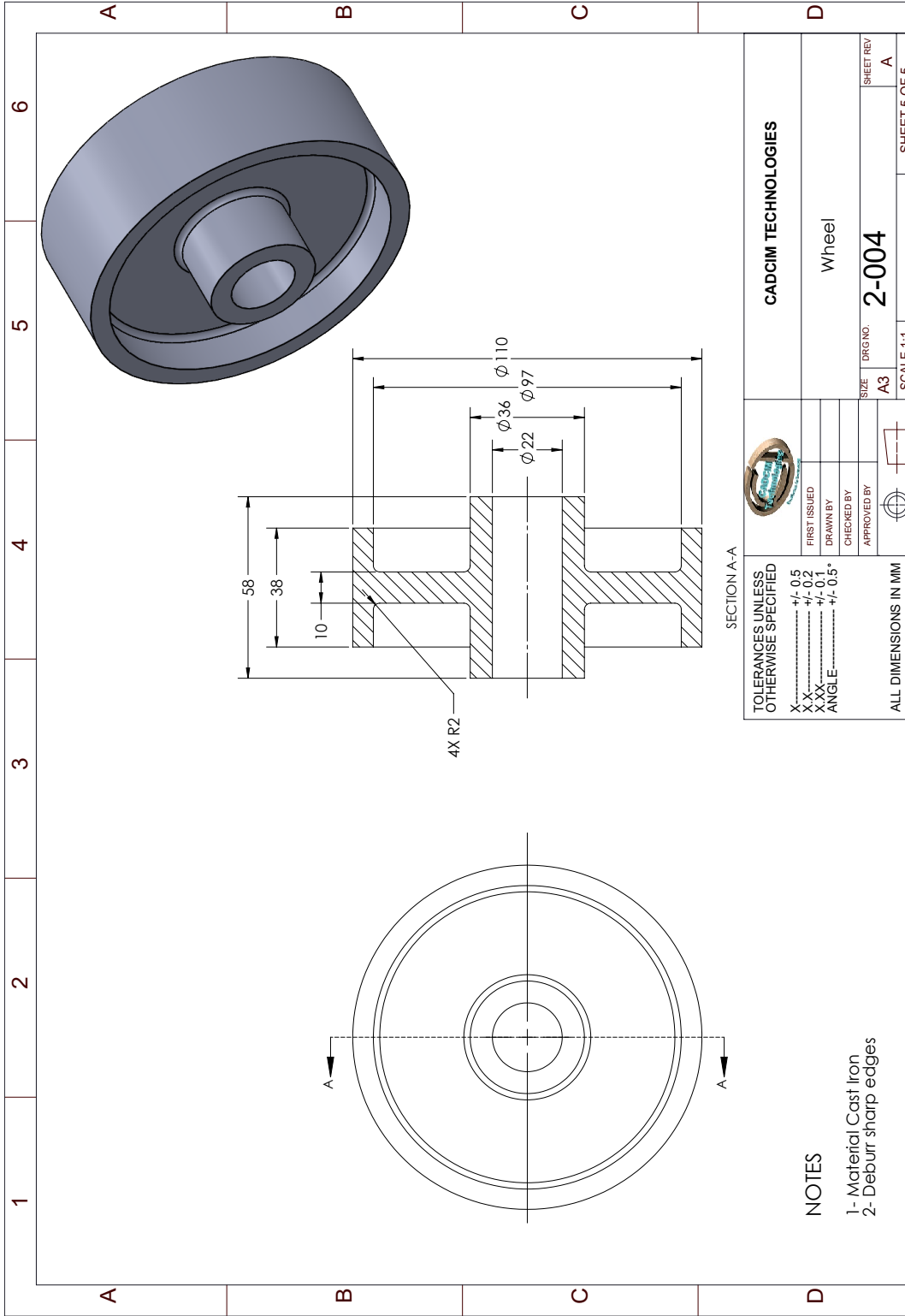

Figure P2-5 Views and dimensions of Wheel